



Edition : 1.0  
Date: (1/25)

## Instruction Manual

# PLASTIC SERVICE CART PSC-2W

Order Code: (T749)

# PLASTIC SERVICE CART



## BEFORE ASSEMBLING

Please read this instruction manual before assembly.



### CAUTION

Before assembly please pay attention to the following points in priority;

**Confirmation of components:** Before assembling, please confirm all parts arrived and are in good order.

**Site for assembly:** Please assemble it on the soft floor such as smooth carpet and flannel blanket. When you assemble on wooden floor, please put thin towels on the floor.

**Points for attention when assembling:** Please wear gloves to ensure that it can be assembled safely, and use two persons to help in the assembly process.

## SAFETY INFORMATION

1. Do not pull this service cart, push it when moving.
2. Must be used on a flat level ground as this Service Cart does not come with brake wheels.
3. Do not tow this service cart with power equipment.
4. Do not overload this service cart over its load rating.



**CAUTION:** Do not attach or mount this product to a vehicle. This may cause personal injury or product damage. Mounting this product to any vehicle in any manner will void warranty.



**CAUTION:** Keep the product on level surfaces. The product may become unstable and tip if stored or moved on an un-level surface, which may cause personal injury or product damage.



**CAUTION:** Do not stand on this product. You may fall which may cause personal injury or product damage.



**CAUTION:** Before moving this product, make sure any objects in the shelf compartments are stable enough and will not roll over and fall out.



# PLASTIC SERVICE CART



## SPECIFICATIONS

Overall size ..... 1170 x 652 x 840mm (LxWxH)

2 Trays ..... 945 x 652 x 105mm (LxWxH)

Wheels:..... Ø127mm (2 swivel & 2 fixed wheels)

Total load rating:..... 250kg (approx 125kg per tray)

Nett Weight:..... 25kg

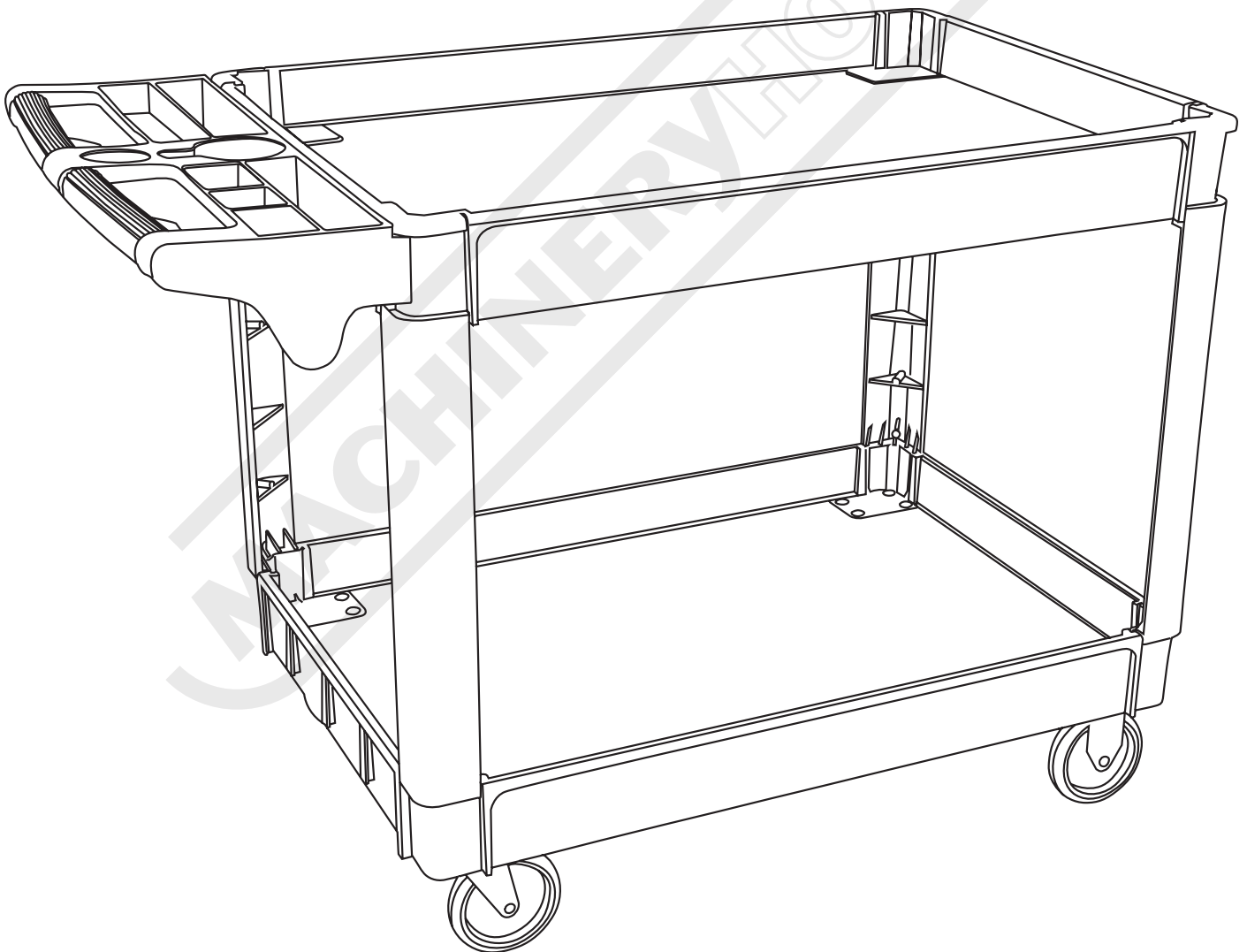









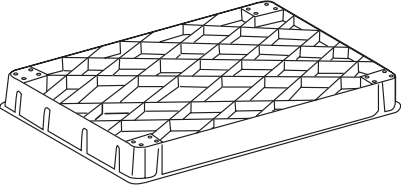

# PLASTIC SERVICE CART

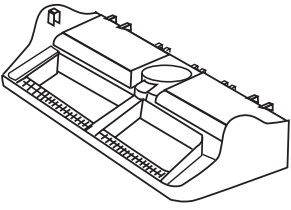

## PARTS LIST

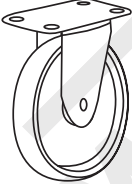
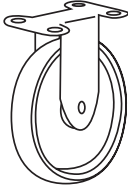
Carefully unpack and spread out all parts in a large uncluttered area.

Familiarize yourself with all parts and compare them with the drawing below to make sure none are missing. Read all assembly instructions before beginning.

 <p><b>A</b> Trays (2pc)</p>	 <p><b>B</b> Left Hand Posts (2pc)</p>	 <p><b>C</b> Right Hand Posts (2pc)</p>
 <p><b>D</b> Handle (1pc)</p>	 <p><b>E</b> Towel Rack (1pc)</p>	 <p><b>F</b> LH Post Caps (4pc)</p>  <p><b>G</b> RH Post Caps (4pc)</p>
 <p><b>H</b> Swivel Wheels (2pc)</p>	 <p><b>I</b> Fixed Wheels (2pc)</p>	 <p><b>J</b> Screws (12pc)</p>
 <p>Includes Spanner</p>	 <p><b>K</b> M8 Bolts (16pc)</p>	 <p><b>L</b> M8 Nuts (16pc)</p>

## ASSEMBLY INSTRUCTIONS

### TOOLS & ASSISTANCE NEEDED



Spanner, Mallet and  
Philips Head Screwdriver

\*Tools not included

### STEP 1

Insert the Towel Rack (E) into the slots on the underside of the Handle (D) as shown below in (Fig. A & B).

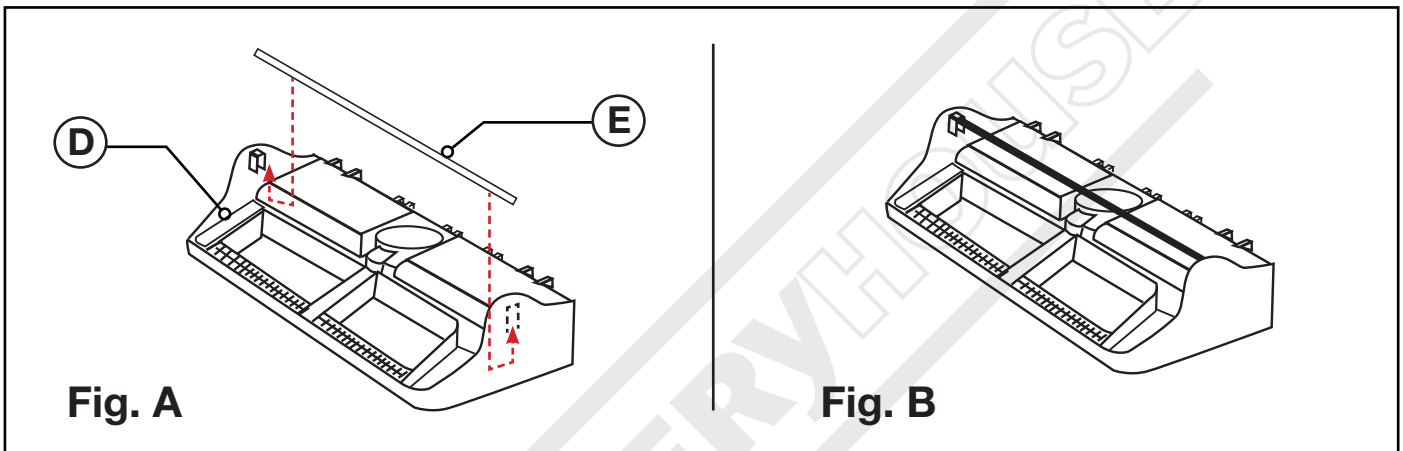

### STEP 2

Place Tray (A) upside down on the work surface. Locate the Handle (D), turn it upside down and use a rubber mallet to tap down flush into the grooves of the side of Tray (C) as shown below.

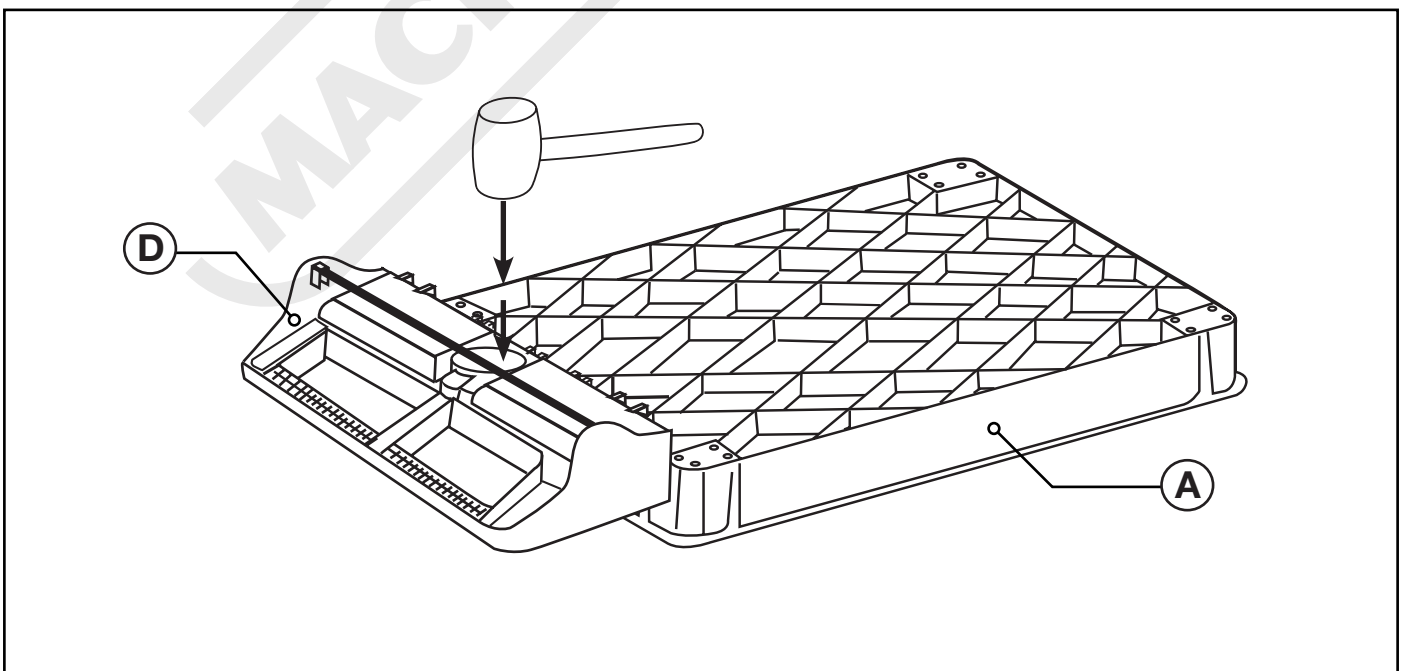

# PLASTIC SERVICE CART



## ASSEMBLY INSTRUCTIONS

### TOOLS & ASSISTANCE NEEDED



Spanner, Mallet and  
Philips Head Screwdriver

\*Tools not included

### STEP 3

Attached the Left & Right Hand Posts (B, C) to the outside corners of the Tray (A) using 3x Screws (J) per post as shown below.

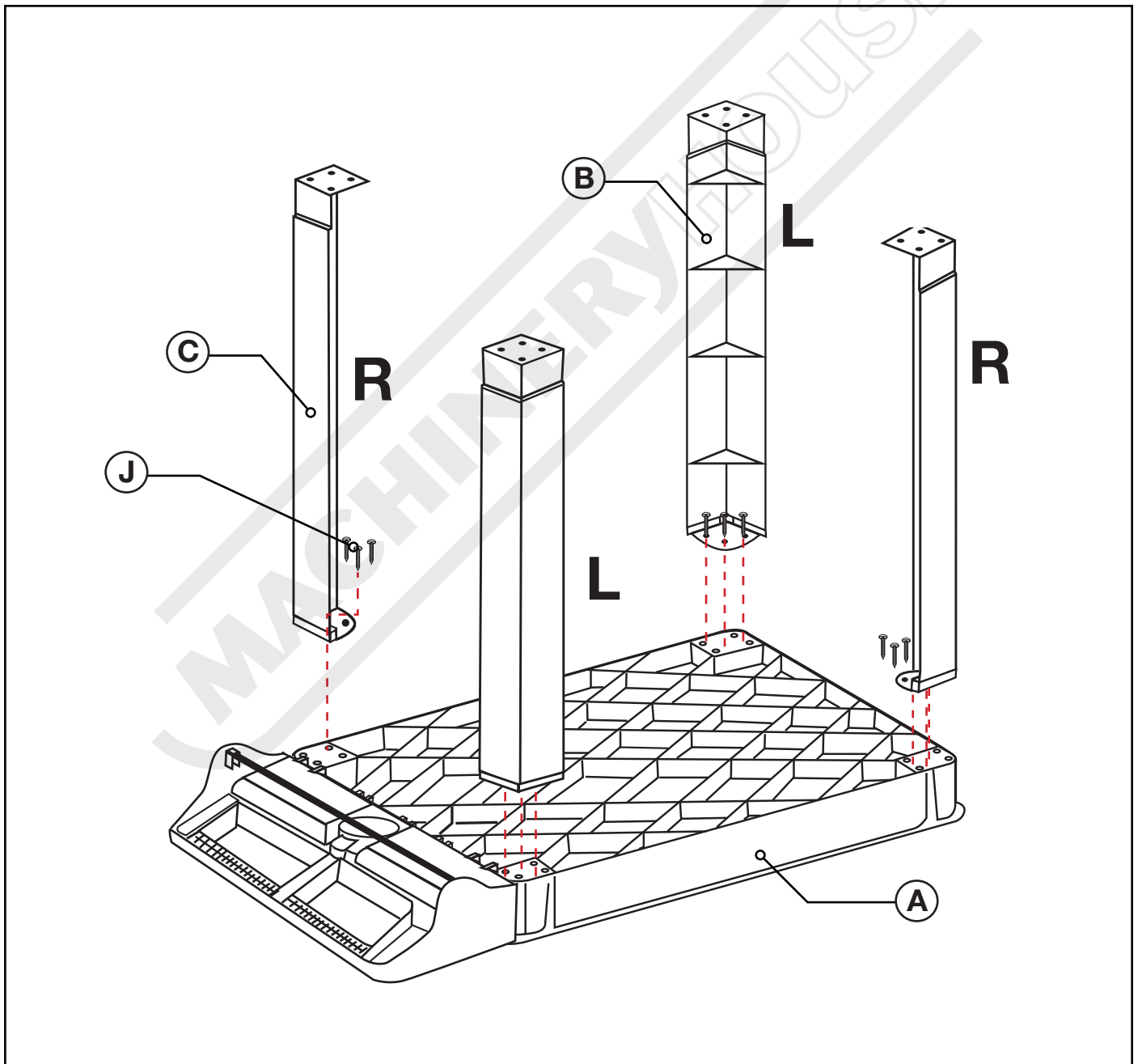

## ASSEMBLY INSTRUCTIONS

### TOOLS & ASSISTANCE NEEDED



Spanner, Mallet and  
Philips Head Screwdriver

\*Tools not included

### STEP 4

Place the Bottom Tray (A) over the LH & RH Posts (B, C). Tap the Bottom Tray (A) down with a mallet to seat flat. Then mount 2 x Swivel Wheels (H) to the Handle (D) side and 2 x Fixed Wheels (I) to the other side using 4 x M8 Nuts (L) and M8 Bolts (K) per Wheel as shown below.

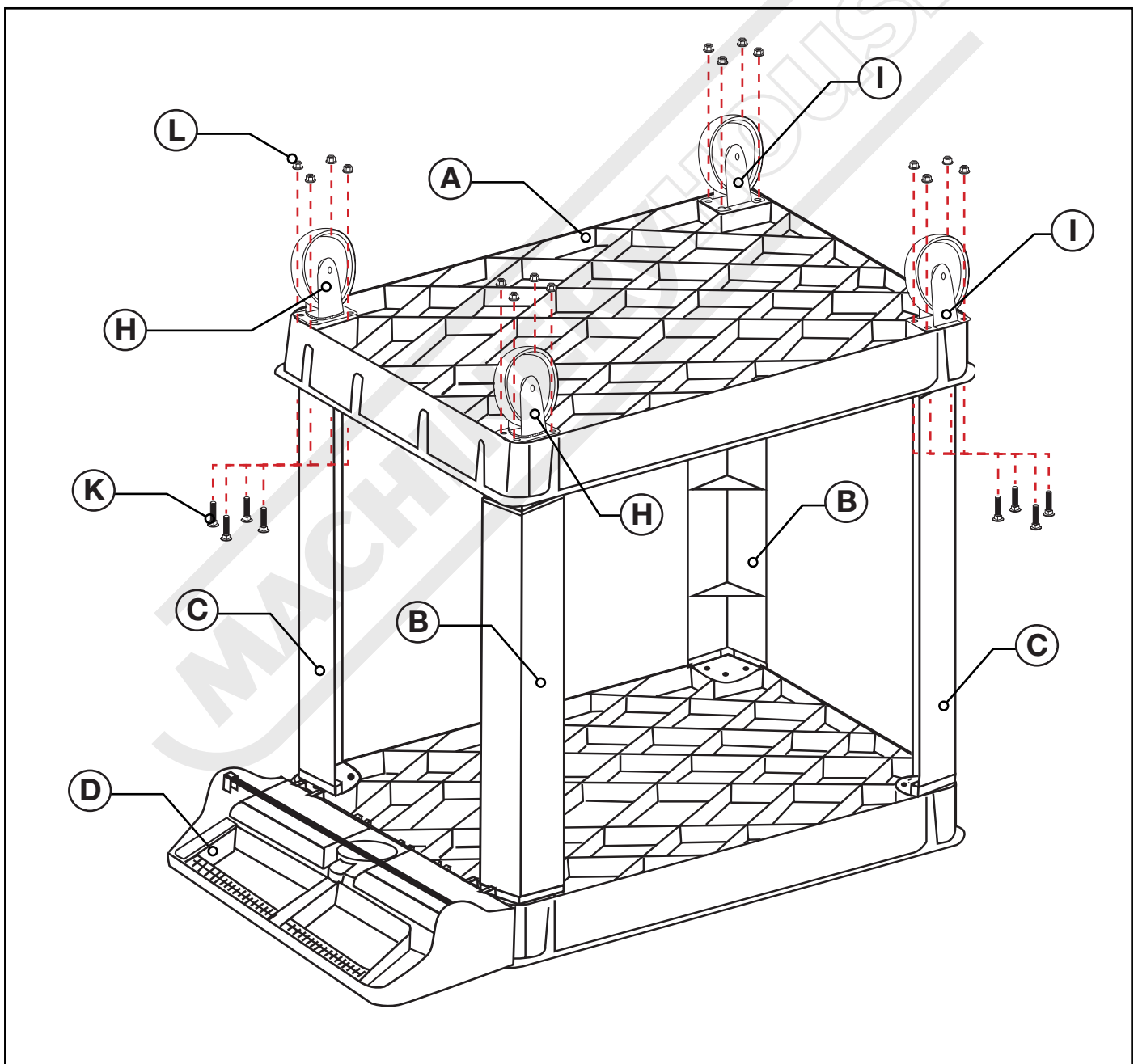

# PLASTIC SERVICE CART



## ASSEMBLY INSTRUCTIONS

### TOOLS & ASSISTANCE NEEDED



Spanner, Mallet and  
Philips Head Screwdriver

\*Tools not included

### STEP 5

Flip the Plastic Service Cart over onto its Wheels. Insert 2 x LH Post Caps (F) and 2 x RH Post Caps (F) into their corresponding corners of the Top Tray (A) and using a mallet, tap the Caps down flush as shown below. The Plastic Service Cart is now ready for use.

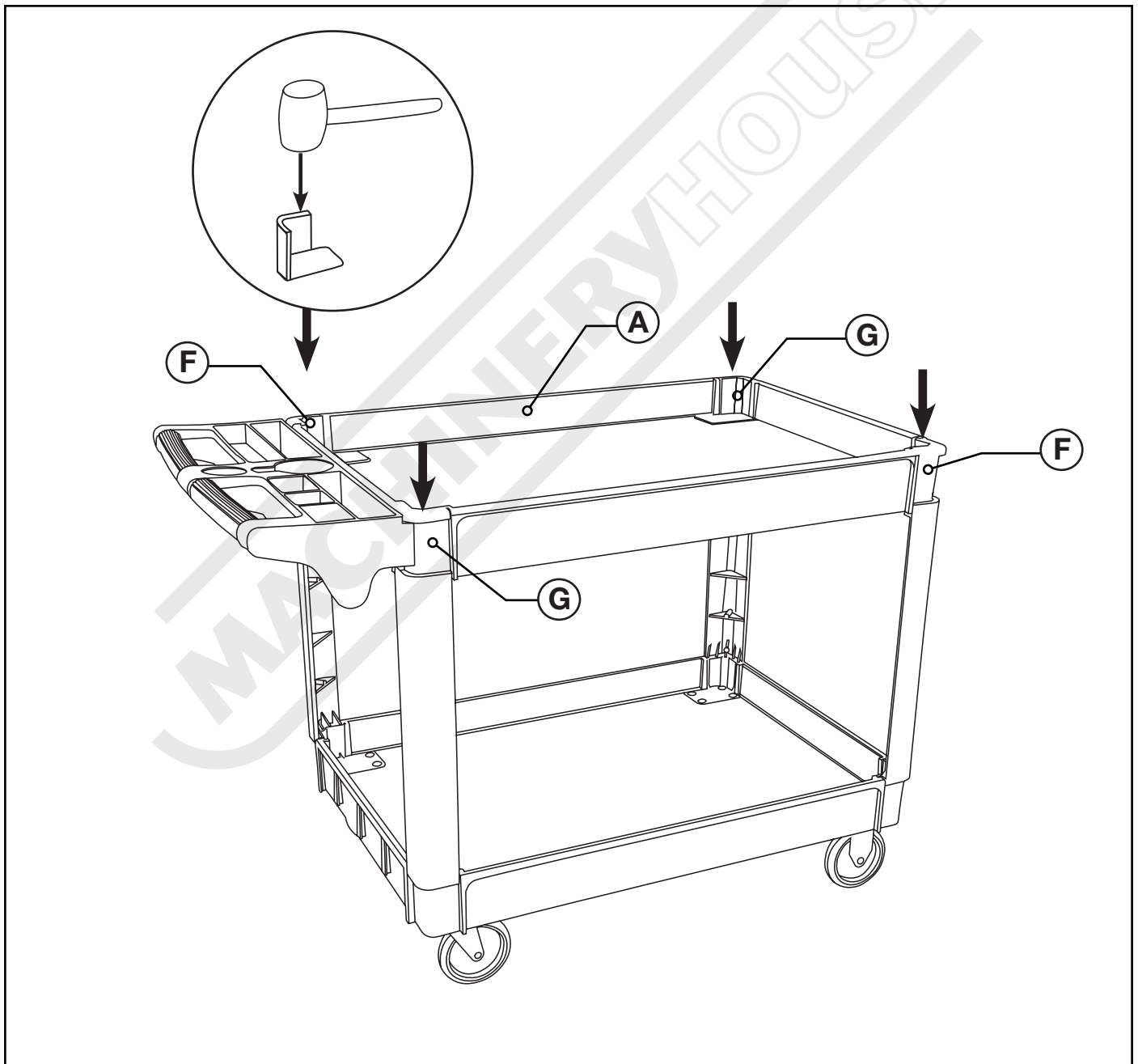



#### **ENVIRONMENT PROTECTION**

Recycle unwanted materials instead of disposing of them as waste. All tools, accessories and packaging should be sorted, taken to a recycling centre and disposed of in a manner which is compatible with the environment. When the product becomes completely unserviceable and requires disposal, drain any fluids (if applicable) into approved containers and dispose of the product and fluids according to local regulations.

Imported by

**HARE & FORBES**  
**MACHINERYHOUSE**

**Australian Distributor**

Hare & Forbes  
Machineryhouse  
Sydney - Melbourne  
Adelaide - Brisbane - Perth

Ph: 1300 202 200  
[www.machineryhouse.com.au](http://www.machineryhouse.com.au)

**MACHINERYHOUSE**

**New Zealand Distributor**

Machineryhouse  
Auckland  
Christchurch

Ph: 0800 142 326  
[www.machineryhouse.co.nz](http://www.machineryhouse.co.nz)